

PRODUCT SPECIFICATIONS



OUTPUT CAPACITIES
14, 18, OR 19 GALLONS PER DAY



* Full warranty details available at www.amana-hac.com.

HUM SERIES

HIGH-CAPACITY FLOW-THRU BYPASS & FLOW-THRU FAN-POWERED HUMIDIFIERS

The Amana[®] brand HUM Bypass and Fan-Powered High-Capacity Humidifiers are a good choice for homes with warm-air heating systems. The durable thermoplastic cabinet resists rust, corrosion, and warping. Its UV-resistant plastic is Architectural Gray.

Standard Features

- Designed to fit today's narrower plenums — as narrow as 10" (HUM-SFTBP) and 14" (HUM-LFTBP, HUM-FP)
- Reversible side panels with snap-lock fittings permit easy change; left- or right-side bypass installation (HUM-SFTBP, HUM-LFTBP)
- Ideal for installations where the return air plenum is not easily accessible (HUM-FP)
- Summer shut-off damper reduces bypass air through the humidifier during the summer months (HUM-SFTBP, HUM-LFTBP)
- Improved wicking and water distribution system accommodates non-level plenums
- Low profile makes unit ideal in limited spaces
- Evaporator pad dispenses water evenly in front of a warm air stream to evaporate and efficiently raise the humidity level
- Durable UV-resistant thermoplastic cabinet resists rust, corrosion and warping

Accessories

- Installation Package (humidistat, self-piercing saddle valve, mounting template and mounting hardware)
- Remote Sensing Relay (HUM-A50)
- Evaporator Pad for HUM-LFTBP and HUM-FP (HUM-1725051)
- Evaporator Pad for HUM-SFTBP (HUM-1725052)
- In-line Filters (HUM-1319051)

SPECIFICATIONS

MODEL	DESCRIPTION	VOLTAGE	MOISTURE OUTPUT CAPACITY			WEIGHT (LBS.)
			LBS. / HOUR	GALS. / HOUR @ 120 °F (GPH)	GALS. / DAY (GPD)	
HUM-SFTBP	Small, Flow-Thru Bypass	24	4.84	0.58	14	10
HUM-LFTBP	Large, Flow-Thru Bypass	24	6.26	0.75	18	11
HUM-FP	Fan-Powered Flow-Thru	110	6.60	0.79	19	15

DIMENSIONS

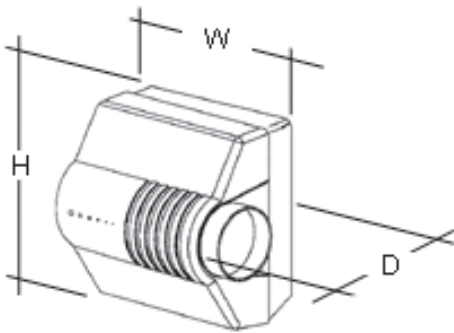

MODEL	HUM-SFTBP	HUM-LFTBP	HUM-FP
Width	9 ⁵ / ₈ "	9 ⁵ / ₈ "	9 ⁵ / ₈ "
Depth	12 ¹ / ₂ "	13 ³ / ₄ "	13 ³ / ₄ "
Height	13 ¹ / ₂ "	18 ⁵ / ₈ "	18 ⁵ / ₈ "
Plenum Opening (H x W)	10" x 9"	16 ⁵ / ₈ " x 10 ⁵ / ₈ "	16 ⁵ / ₈ " x 13 ¹ / ₈ "
Bypass Opening Diameter	6"	6"	N/A

HUMIDIFIER SIZING CHART

MODEL	RECOMMENDED MAX. HOME SIZE (SQURE FEET)			RECOMMENDED MAX. HOME SIZE (CUBIT FEET)			GPD* @ 120°F FOR AN 8' CEILING
	TIGHT	AVERAGE	LOOSE	TIGHT	AVERAGE	LOOSE	
HUM-SFTBP	3,333	2,121	1,647	26,664	16,968	13,016	14
HUM-LFTBP	4,285	2,725	1,955	34,280	21,800	15,640	18
HUM-FP	4,525	2,880	2,065	36,200	23,040	16,520	19

* Gallons per day

Note: Ratings and calculations are from ARI 630. Some installations may allow for an additional bypass tube, which can boost performance by approximately 20%. Requires purchase of additional parts.

Tight House: Insulated walls and ceilings; vapor barriers; weather stripping on doors and windows; snug doors, windows and fireplace damper. One-half air change per hour.

Average House: Insulated walls and ceilings; vapor barriers; loose doors, windows and fireplace damper. One air change per hour.

Loose House: No insulation, storm doors, storm windows, weather stripping or vapor barriers. Two air changes per hour.

